



COMMERCIAL REFRIGERATION EQUIPMENT FOR THE PROFESSIONAL

www.fosterrefrigeration.com
Toll free: 1.833.367.8373

Model #:
FPP-93-HC

Prep Table Series:
Triple Door Pizza Prep Table - Hydrocarbon Refrigerant



FPP-93-HC

- Cabinet Construction**
 Stainless steel exterior and stainless steel interior including floor. Matching aluminum back panel.
- Stainless Steel Insulated lid** keeps pan temperatures colder for fresh food and to minimize condensation. Easily removed for cleaning.
- Rounded corner** design inside of cabinet for easy cleaning.
- Standard door features:**
 Heavy duty pull handle. Each door features two spring loaded hinges with automatic closing.
 90° Stay-open feature for easy loading and unloading.
- Refrigeration system** holds 33°F to 41°F (0.5°C to 5°C), for the best in food preservation.
- CAREL Electronic Control System**
 Fully adjustable temperature set points and defrost frequency. Self monitors to diagnose service status. Carel is a world leader in refrigeration controls.
- Shelf:** Adjustable, heavy duty PVC coated shelves.
- Standard heavy-duty casters** make it easy to move and clean underneath.



Rough-In Data

Specifications subject to change without notice.

Model	Doors	Shelves	Cabinet Dimensions (inches) (mm)			Capacity Cubic ft./ Liter	HP	Voltage	Amps	NEMA Config.	Crated Weight (pounds) (kg)
			W	D	H*						
FPP-93-HC	3	3	91 7/8 2334	36 7/8 937	42 7/8 1088	24.2 477	1/4	115/60/1	5.3	5-15P Ⓜ	609 276

*Height measurement includes casters.



STANDARD FEATURES

Hydrocarbon Refrigeration System

- Foster's innovative and environmentally friendly design incorporates R-290 hydrocarbon refrigerant. Hydrocarbon refrigerants are naturally occurring and have zero ozone depletion potential (ODP-0) and a global warming potential of three (GWP-3).
- Factory balanced, self contained refrigeration system maintains temperatures of 33°F to 40°F (0.5°C to 5°C).

Digital temperature control and monitoring system

- Digital temperature control and monitoring is powered by Carel. Carel is a world leader in refrigeration system controls.
- Automatic evaporator fan motor delays.
- Digital display for real time monitoring.
- Auto-defrost function.

Doors

- Stainless steel exterior with stainless steel liner.
- Positive self closing/sealing with removable gasket for cleaning or replacement.
- Stay open feature allows door to remain open at 100° for easy loading or unloading.

Cabinet Construction

- Foster prep tables feature **full** stainless steel exterior body with galvanized steel back panel. The interior cabinet is **full** stainless steel construction with radius cornered floor pan for easy cleaning.
- Foamed in place CFC and HCFC free polyurethane insulation enhances the structural strength of the cabinet and increases energy efficiency.
- Insulated top lid helps maintain safe product temperatures.
- 19 7/16" deep cutting board for optimal preparation work.
- Bottom frame is fitted with 4" casters equipped with locks on the front.

Shelving & Inserts

- One adjustable epoxy coated shelves (ETL Sanitation approved).
- Top pan rail holds up to (12) 1/3 size, 6" deep food pan inserts.
- Pan rail is air cooled from the bottom.
- Each shelf can accommodate up to 90 pounds each.

PLAN VIEW

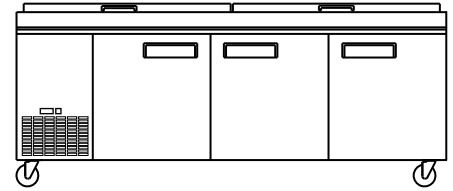

FRONT VIEW

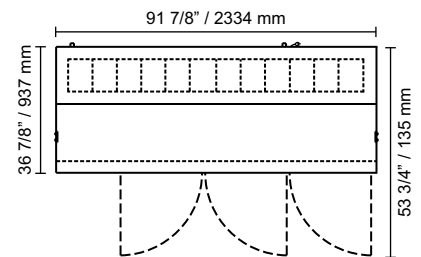

PLAN VIEW

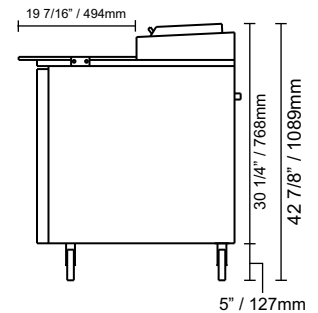

SIDE VIEW